

© 2008 Mazda Motor of America, Inc.

Subject: STARTER MOTOR WILL NOT CRANK AND ENGINE DOES NOT START (INTERMITTENTLY)	Bulletin No: 01-037/08
	Last Issued: 07/17/2008

APPLICABLE MODEL(S)/VINS

2004 - 2008 Mazda3 vehicles (NOT including Mazdaspeed3)

DESCRIPTION

On some vehicles, the starter motor will not crank and the engine does not start. The problem is intermittent. This is caused by poor contact of the connector for the magnet switch terminal "S" in the starter motor.

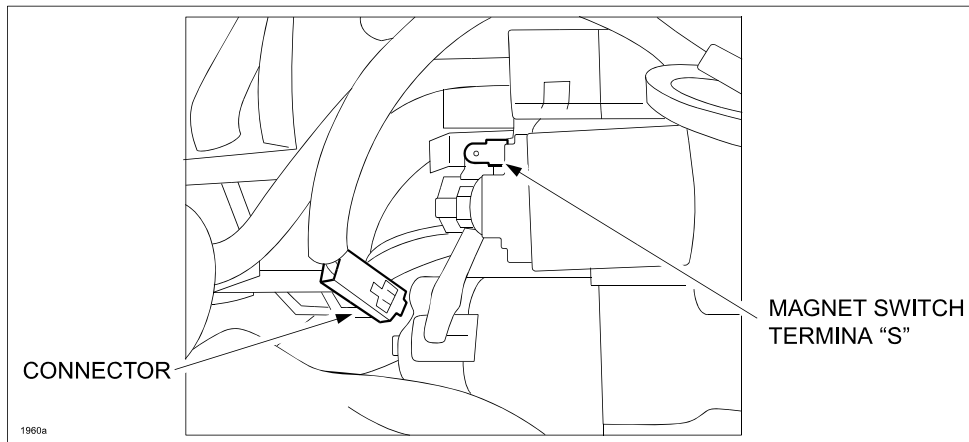

Customers having this concern should have their vehicle repaired using the following repair procedure where the connector for the magnet switch terminal "S" is replaced with a short cord set.

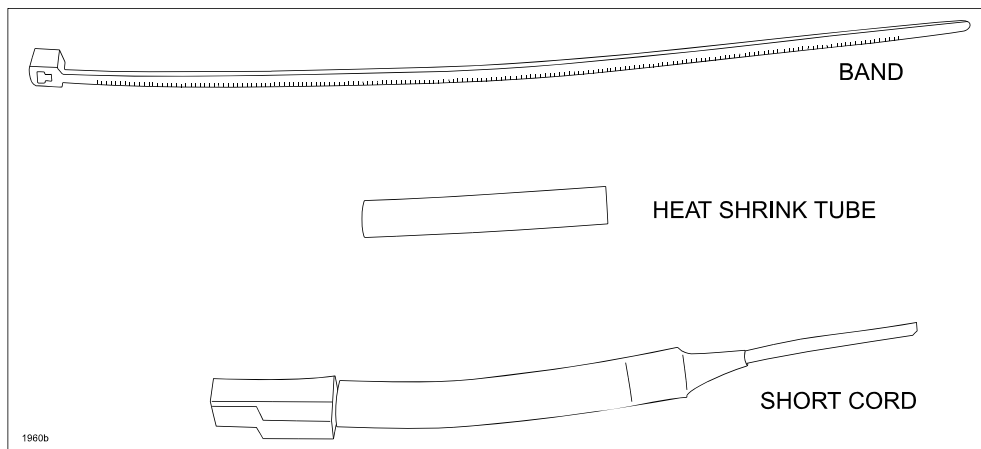

CONSUMER NOTICE: The information and instructions in this bulletin are intended for use by skilled technicians. Mazda technicians utilize the proper tools/equipment and take training to correctly and safely maintain Mazda vehicles. These instructions should not be performed by "do-it-yourselfers." Customers should not assume this bulletin applies to their vehicle or that their vehicle will develop the described concern. To determine if the information applies, customers should contact their nearest authorized Mazda dealership. Mazda North American Operations reserves the right to alter the specifications and contents of this bulletin without obligation or advance notice. All rights reserved. No part of this bulletin may be reproduced in any form or by any means, electronic or mechanical---including photocopying and recording and the use of any kind of information storage and retrieval system ---without permission in writing.

REPAIR PROCEDURE

1. Verify customer concern.

NOTE: If the following symptoms are present, address them before proceeding.

- After turning the ignition on, the Security Indicator Light does not turn off after 3 seconds, and remains on, flashing repeatedly. This could be a sign of a frozen main relay (in extreme cold conditions) or a possible immobilizer issue. For immobilizer concerns, reference section 09-02A in the the Workshop Manual for diagnosing the system.
- On automatic transaxle vehicles with the vehicle in Park (when the condition occurs), the Shift Position Indicator Light will not be illuminated around P, and if the vehicle is shifted to N the engine can be started. This could be caused by an issue with mechanical movement of the shifter cable at the inhibitor switch, or an issue with the switch circuit.

2. Record the customer's radio station presets.
3. Disconnect the negative battery.
4. Lift the vehicle up.
5. Remove the engine under cover.
6. Disconnect the connector from the magnet switch terminal "S" of the starter motor.
7. Clean the magnet switch terminal "S" of the starter motor, then polish it using fine sandpaper.
8. Cut the harness near the connector.

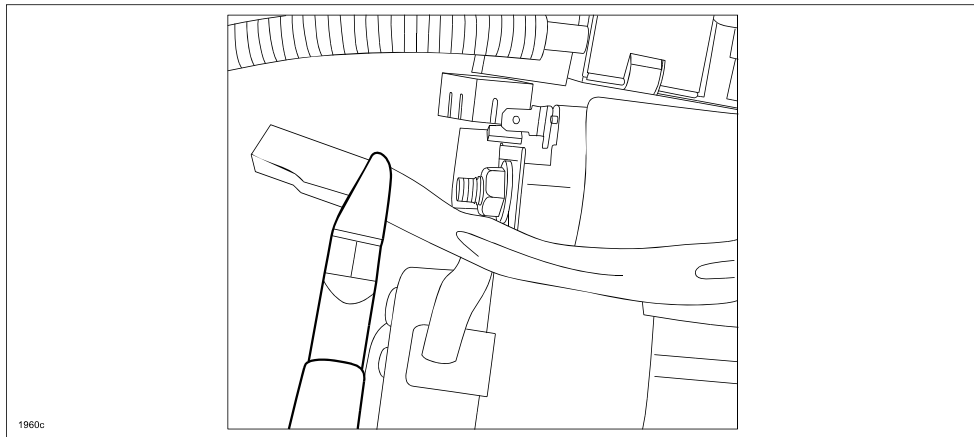

9. Cut the black wire cover off by 35 mm as shown.

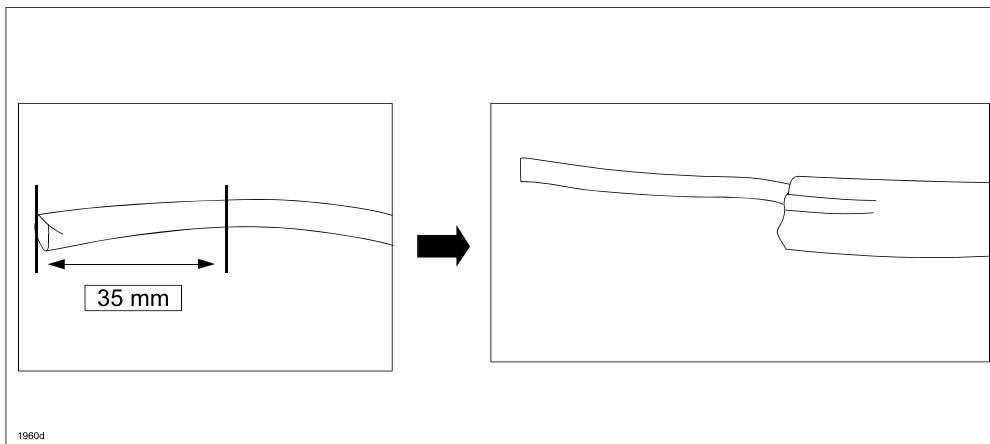

10. Remove the wire covering from the harness and short cord by 10 mm as shown.

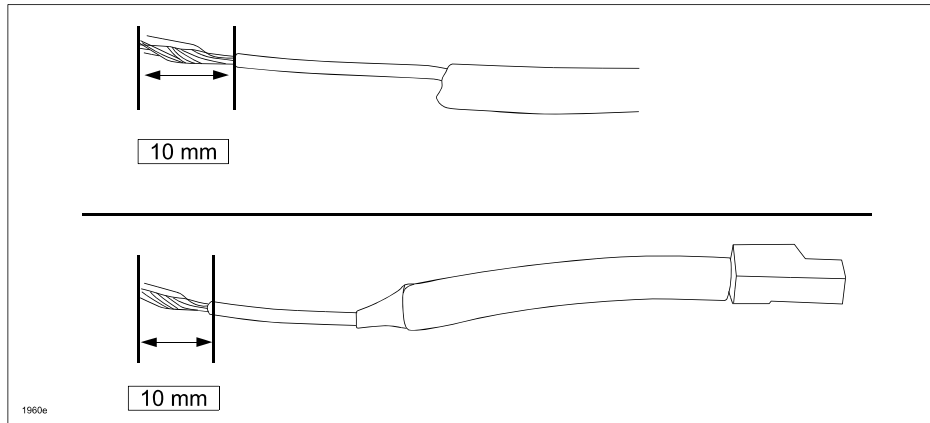

11. Twist the wires of the harness and the short cord together and solder them.

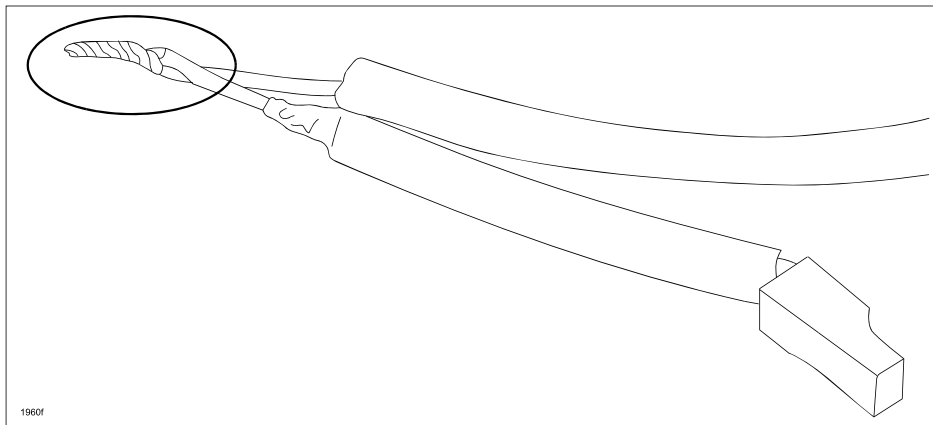

12. Cover the soldered wires with a heat shrink tube (length: 30 - 35 mm) as shown.

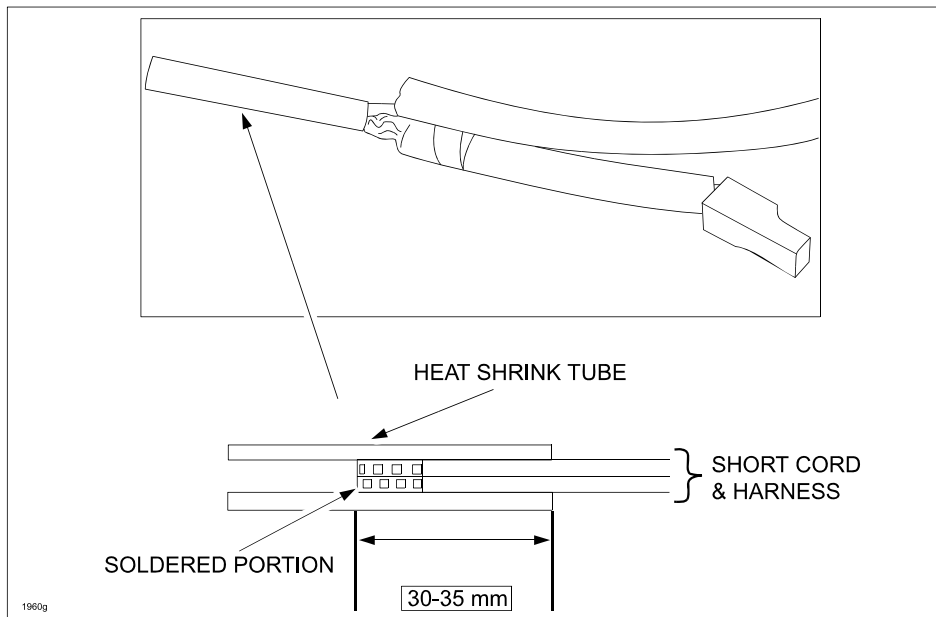

13. Place the solder iron close to the heat shrink tube to allow it to shrink from the heat of the solder iron.

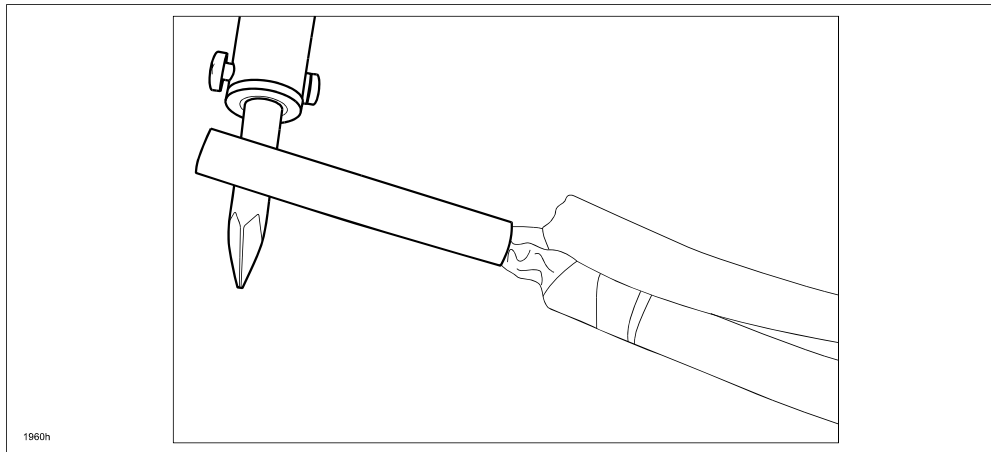

14. Connect the short cord (with modified connector) on the magnet switch terminal "S."

15. Tie the short cord to the main harness with the band.

NOTE: Cut off the excess portion of the band.

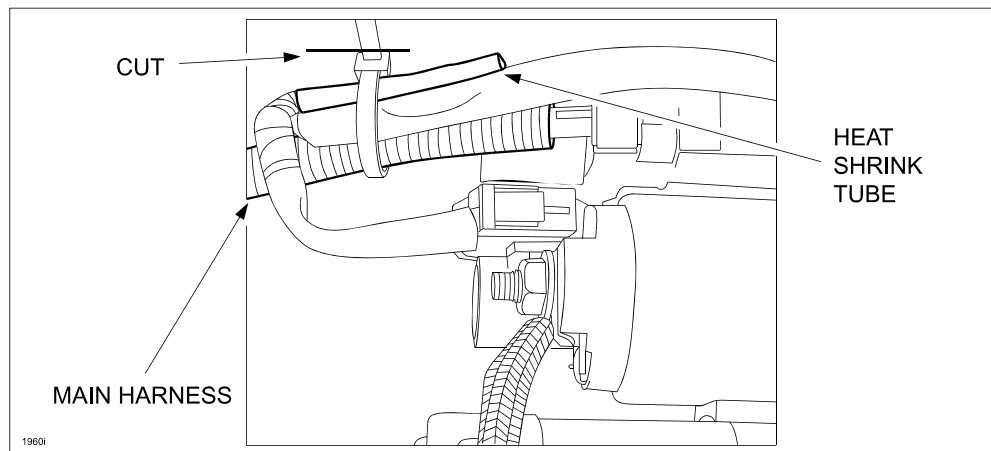

16. Re-install the parts in the order of removal.

17. Connect the negative battery cable.

18. Verify repair.

19. Enter the customer's radio station presets and set the clock.

PART(S) INFORMATION

Part Number	Description	Qty.
BAY0-67-SH0	Short Cord Set	1

WARRANTY INFORMATION

NOTE:

- This warranty information applies only to verified customer complaints on vehicles eligible for warranty repair.
- This repair will be covered under Mazda's New Vehicle Limited Warranty term.
- Additional diagnostic time cannot be claimed for this repair.

Warranty Type	A
Symptom Code	61
Damage Code	9R
Part Number Main Cause	BAY0-67-SH0
Quantity	1
Operation Number / Labor Hours:	XXD1YXRX / 0.4 Hrs